

# Spring Mat Assemblies – Bushings

www.vibrationmounts.com Phone: 516.328.3662 Fax: 516.328.3365

- **MATERIAL:** Isolator – Synthetic Rubber  
Retaining Plate – Steel, Galvanized

- **TO BE USED WITH SPRING MAT ASSEMBLIES, V11Z20MSM SERIES**

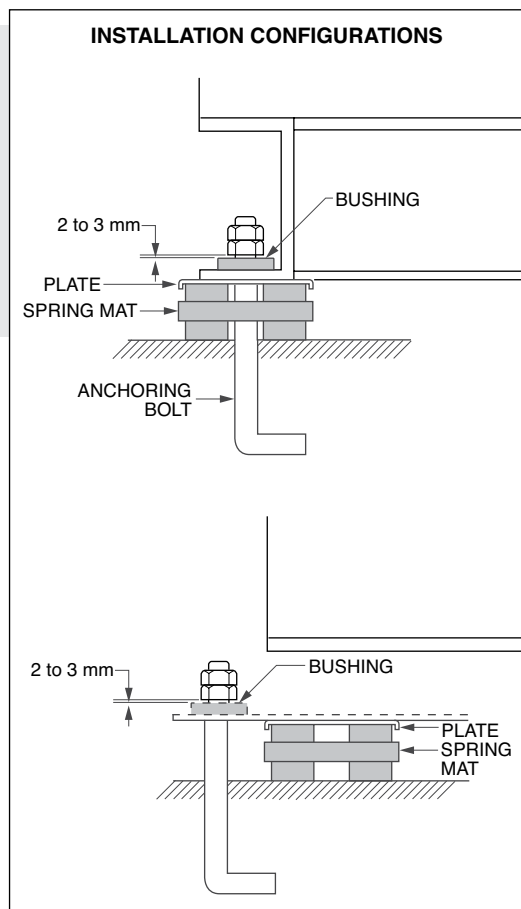

Metric

### APPLICATIONS

- AIR CONDITIONING EQUIPMENT
- DISTRIBUTION PIPE SUPPORTS
- VARIOUS INDUSTRIAL MACHINERY

### FEATURES:

- Far superior to rubber mats in its ability to reduce vibration.
- Simple to use with convenient options.

### HOW TO USE:

1. V11Z20MSM020C to V11Z20MSM200C can be inserted from the side into an existing installation by cutting the spring mat to allow the bolt to pass to the center.
2. When the bottom of the equipment does not contact the entire spring mat, please use the optional metal plate.
3. If it is necessary to guard against earthquakes, please verify the strengths of anchoring bolts and attaching components.

**NOTE:** Dimensions in ( ) are inch.

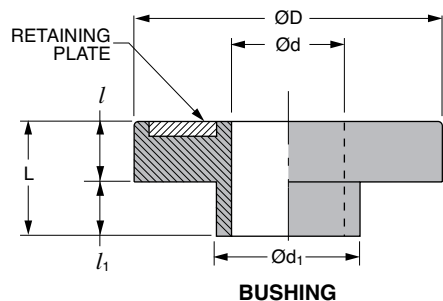

Catalog Number	D	d	d <sub>1</sub>	L	l	l <sub>1</sub>
V11Z21MSMB10	26 (1.02)	10.5 (.41)	12.5 (.49)	8.6 (.34)	4.6 (.18)	4 (.16)
V11Z21MSMB12	30 (1.18)	12.5 (.49)	14.5 (.57)	11.3 (.44)	6.3 (.25)	5 (.20)
V11Z21MSMB16	36 (1.42)	17 (.67)	19 (.75)	13.6 (.54)	8.6 (.34)	6 (.24)
V11Z21MSMB20	44 (1.73)	21 (.83)	23 (.91)	15.2 (.60)	9.2 (.36)	6 (.24)
V11Z21MSMB24	52 (2.05)	25.5 (1.00)	27.5 (1.08)	17.5 (.69)	11.5 (.45)	6 (.24)