



Base Mounts – Silicone Gel Type

www.vibrationmounts.com Phone: 516.328.3662 Fax: 516.328.3365

- **MATERIAL:** Stud – Steel, Trivalent Chromate Plated
Body – Silicone Gel
Flange Plate – Stainless Steel

- DAMPS LOW FREQUENCY VIBRATIONS
- FOR SMALL TO INTERMEDIATE LOAD APPLICATIONS
- CAN BE USED WHEN SPACE IS LIMITED
- TO BE USED IN COMPRESSION ONLY

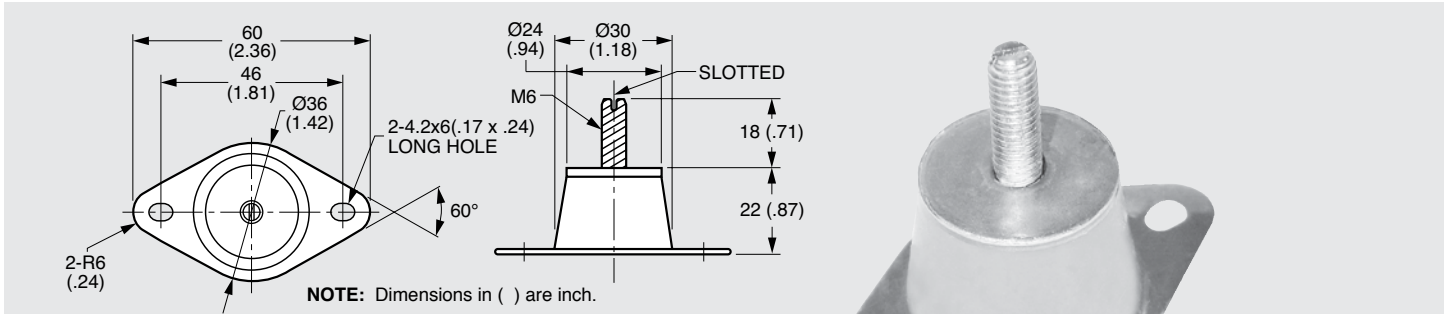

Metric

TEMPERATURE RANGE: -40°C to +200°C (-40°F to +392°F)

Catalog Number	Optimum Load kgf/leg (lb./leg)
V10Z61MSF02	1.25 to 3.25 (2.8 to 7.2)
V10Z61MSF05	3.25 to 7.5 (7.2 to 16.5)
V10Z61MSF10	7.5 to 12.5 (16.5 to 27.6)

